

DINA-DRI / LITE

DIN rail mounted – Advanced lighting controller

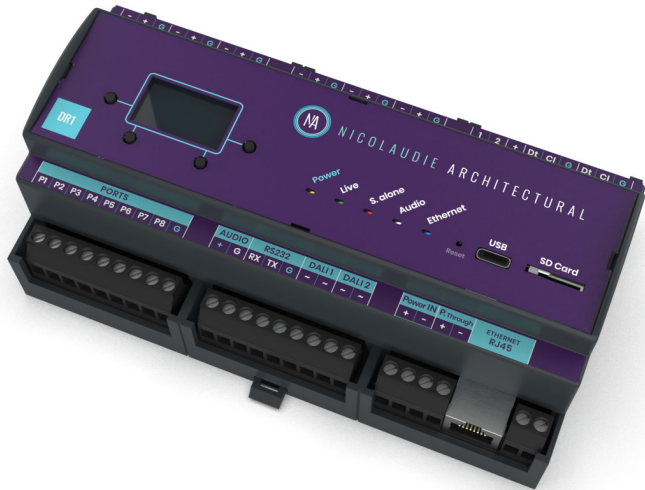

Overview

The DINA-DRI is a lighting controller for the most ambitious of projects, outputting 6 DMX universes (3072 channels) in 20 zones. Trigger lighting scenes using calendar triggers and conditional rules with the New Stand Alone engine. Connect to the Nicolaudie Cloud for remote control and management.

Lighting levels, color and effects can be programmed from a PC, Mac, Android, iPad or iPhone using software from our website.

www.nicolaudie.com/dina.htm

Key Features

- DMX512 / eDMX / LED Pixel Stand Alone controller
- DRI 6x Universes (3072 channels)
- DRI LITE 2x Universes (1024 channels)
- Output Universes via DMX512 (up to 6 universes) and Artnet/sACN (up to 12 universes)
- SUT Technology allows the device to be upgraded with more universes & used with other Nicolaudie Group software
- USB & Ethernet connectivity for programming and control
- Stand Alone mode with 2000 scenes & 20 zones
- 16MB flash memory & microSD slot
- 8 dry contact trigger ports
- RDM compatible (set / check DMX addresses)
- Windows/Mac software for programming
- iPhone/iPad/Android apps for remote control and programming
- Compatible with NATouch-1 wall controller
- Control 2 external relays
- Nicolaudie Cloud * : Remote control and management via internet connection (subscription required)
- Audio triggering / sound-to-light *
- RS232 protocol scene control *
- **Future features**
- Direct support for LED Pixel Tape *
- DALI *

* DINA DRI LITE optional features

Technical Data

Input Power	12v DC (8-15V range)
Output Protocol	DMX512 (x6), eDMX, LED Pixel (SPIx2)
Programmability	PC, Mac, Android, iOS
Connections	USB-C Ethernet Scew terminals for - 6 DMX / RDM Universes - LED Pixel (coming) - 2 DALI loops (coming) - 8 Contact ports - Relay (coming) - 12v power-in & pass through - RS232 scene trigger - Audio in Battery holder (LIR2032 3.6v), microSD slot
TCP Connections	10 + 1 cloud
Memory	16MB flash, SD Card (max 32Gb, FAT32)
Environment	IP20
Buttons	2 scene, 2 page, 1 reset
Dim / Weight	160 x 91 x 62 mm 317g
OS Requirements	Mac OSX 10.13+, Win 10/11

Optional

12V AC/DC power supply

DIN rail mounted - Advanced lighting controller		DINA-DR1	
Technical datasheet	Revision date 21 July 2023	www.nicolaudie.com	V 1.03

Connections

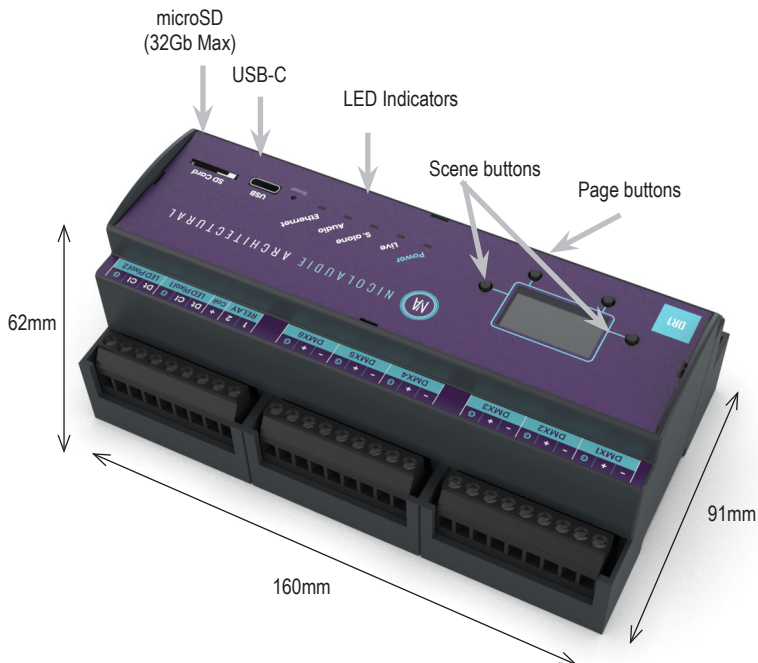
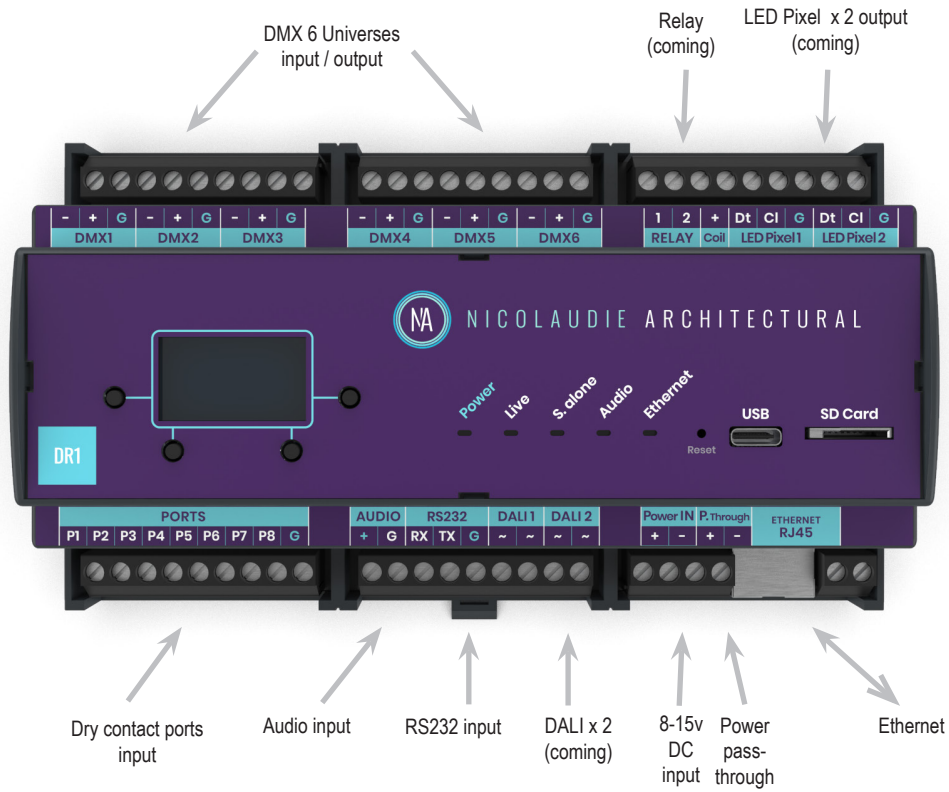

DIN rail mounted - Advanced lighting controller		DINA-DR1	
Technical datasheet	Revision date 21 July 2023	www.nicolaudie.com	V 1.03

EASY INSTALLATION

1. Mount a DIN Rail or DIN Rail Enclosure against a wall

2. Connect the wires

POWER: Connect 12V DC ACDC supply. The DINA-DR1 can accept 8v-15v. Be sure to not invert the + and the ground.

DMX: Connect the DMX cables from one of the 6 universes to the lighting receivers

3. Clip the DINA-DR1 onto the DIN RAIL

On the back of the interface housing is a channel designed to accept a DIN Rail with a black plastic clip which secures the interface.

To mount: Slide the mounting teeth behind the top of the rail and then rotate downwards to engage the clip.

To dismount: At the lower edge of the interface you will see a plastic clip. Pull this down to release interface from the rail.

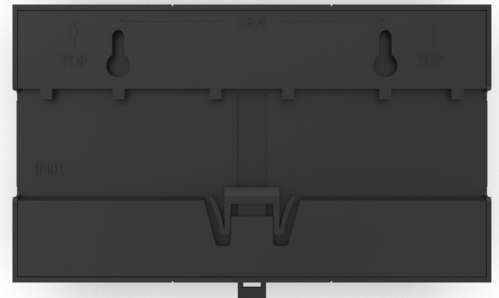

SETTING UP THE CONTROLLER

Programming the Controller

The controller can be programmed from a PC or Mac, iPad, iPhone or Android device using the software and apps listed below. Refer to the corresponding software manual for more information.

Windows / Mac Programming Software



ESA Pro 2 Software (Windows/Mac) - designed for lighting professionals. Includes multi-zone programming, a time-line editor, automations, advanced triggers (TCA), full color-management and a standalone mode simulator.
nicolaudie.com/esapro2.htm



ESA2 Software (Windows/Mac) - Single zone, step-based programming with time / port triggers. It only requires a few minutes to setup the software and gain full control of any kind of lighting.
nicolaudie.com/esa2.htm

Apple iOS and Android Apps



Arcolis Designer

Multi-zone programming from a tablet or smartphone. Arcolis gives you the freedom to move around the site, controlling and programming an installation in real-time without being restricted to a laptop and USB cable in the control room.

Note: It is not possible to import a show created in one programming software into another.

Firmware and settings can be updated using Hardware Manager (installed with PC/Mac programming software) or with Hardware Tools (iOS and Android App Stores).



Hardware Manager (Windows/Mac) - Firmware, clock
<https://eu-tools.n-g.co/Release/HardwareManager.dmg>
<https://eu-tools.n-g.co/Release/HardwareManagerBeta.exe>



Hardware Tools

Update firmware, set clock, settings, etc.

DIN rail mounted - Advanced lighting controller		DINA-DR1	
Technical datasheet	Revision date 21 July 2023	www.nicolaudie.com	V1.03

CONNECTIONS AND TRIGGERING

DMX512

Connect up to 6 DMX universes to the controller using the DMX connections. LITE models ship with licences for 2 universes but can be upgraded.

LED INDICATORS

- POWER: orange LED is ON when the interface is powered on
- LIVE MODE: green LED flashes when software is connected
- STANDALONE MODE: red LED is ON when the controllers is running in standalone mode
- AUDIO: white LED flashes when the controller detects a beat or pulse from the microphone or Line In
- ETHERNET: blue LED flashes when the controller is connect to a local network

AUDIO / SOUND-TO-LIGHT

The controller has sound-to-light capability running in standalone mode. Audio beats are detected using the Line In port. The signal should be line level. The audio LED will flash white when a beat is detected. Programming/configuration of sound-to-light must be made using ESA Pro 2. Refer 'Audio Triggering' in ESA Pro 2 manual.

BATTERY

The 3.6v rechargeable LIR2032 battery provides power to store the date and time and remember last played scene in case of a power cut.

Warning: Battery should not be relied upon 1) for daily power outages due to life of ~500 cycles or 2) below 0°C. Do not

PORTS

Use up to 8 external trigger ports (dry contacts)
Connect G and P1 to trigger port #1
Connect G and P2 to trigger port #2...
Use the ports to trigger actions in our software such as starting, stopping or pausing a scene.

RS232

Make a cable using the 3 pins : TX, RX and G (GND)

Set the RS232 communication parameters to :

9600bds, 8 bits, no Parity, 2 Stop bits

Messages should be hexadecimal not decimal (ie. 1 = 01, 255 = ff etc.)

- To play a scene, send 4 bytes : 1 x y 255
- To stop a scene, send 4 bytes : 2 x y 255
- To pause a scene, send 4 bytes : 3 x y 255
- To release a pause, send 4 bytes : 4 x y 255
- To reset a scene, send 4 bytes : 5 x y 255

When (y)=0, (x) can be set between 0 and 255 to trigger scenes 0-255

When (y)=1, (x) can be set between 0 and 255 to trigger scenes 256-511

... and so on, up to (y)=7) and (x) =208 for scene 2000.

A page can contain 1-2000 scenes as long as the total number on all pages does not exceed 2000.

The index of a scene can be found by looking in the file /show/show_map.xml on the microSD.

Examples:

0x01 0x02 0x00 0xFF to start scene 2

0x01 0x05 0x00 0xFF to start scene 5

0x01 0x10 0x05 0xFF to start scene 1296

HARDWARE SETTINGS DISPLAY

It is possible to display most of the controller settings from the device screen. Press and hold the 2 zone buttons (tick and cross) for 2 seconds to display the settings. You can then navigate with the scene buttons. Repeat the operation to leave the display mode.

The most important settings can be seen from the device display: date/time, firmware version, serial number, network settings, etc.

LOG MANAGEMENT

The controller offers the possibility to store activity logs on the SD CARD or on a syslog server. This option can be activated from Hardware Manager on the Settings tab and could be very helpful in servicing an installation. We recommend using the 'Store on SD Card' option for debugging only ; Do not leave it on permanently as this will greatly reduce the longevity of the SD card.

DIN rail mounted - Advanced lighting controller		DINA-DR1	
Technical datasheet	Revision date 21 July 2023	www.nicolaudie.com	V 1.03

SUT Licence Upgrades

Extra hardware features and software compatibility can be unlocked by purchasing upgrades or adding 30 day free software trials at https://store.nicolaudie.com/my_interfaces

1. Click + *Register a new Interface* and download the SUT driver software. Follow the on-screen prompts.

2. Once registered, select your interface on the left. You can buy new features and software compatibility, change the device name or transfer the device to a new owner.

Any licence changes will be *automatically* synchronised the next time you connect your interface to most Nicolaudie Group software while connected to the internet. Currently installed licences can be checked using HardwareManager on the SUT screen.

TROUBLESHOOTING

The controller is not detected by the computer

- Be sure that the latest software version is installed from our website
- Connect by USB and open the Hardware Manager (found in the software directory). If it is detected here, try to update the firmware. If it is not detected, try the method below.

• Bootloader Mode

Sometimes the firmware update may fail and the device may not be recognized by the computer. Starting the controller in 'Bootloader' mode forces the controller to start at a lower level and in some cases allows the controller to be detected and the firmware to be written. To force a firmware update in Bootloader Mode :

1. Power off your interface
2. Start HardwareManager on your computer
3. Activate Bootloader by holding down buttons 2 & 3 (under the screen) while connecting power. Instead of connecting power you can also press the reset button. If successful, the green, red and white LED will flash and your interface will appear in HardwareManager with the suffix `_BL`.
4. Update your firmware

The lights are not responding

- Check the DMX +, - and GND are connected correctly
- Check that the driver or lighting fixture is in DMX mode
- Be sure that the DMX address has been set correctly
- Check there are no more than 32 devices in the chain
- Check that the red DMX LED is on or flickering.
- Connect with the computer and open Hardware Manager (found in the software directory). Open the DMX Input/Output tab and move the faders. If your fixtures respond here, it is possibly a problem with the show file

Green, red and white LED flashing

The controller is in bootloader mode. This is a special 'startup mode' which is run before the main firmware loads. Try re-writing the firmware with the latest HardwareManager available from the downloads section of our website.